

#### 4. パドルの寸法

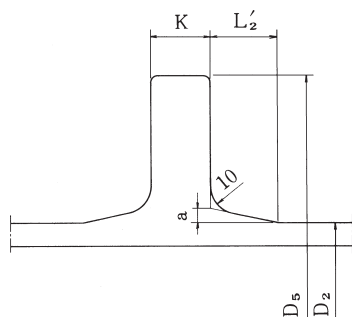

単位 mm

呼び径 D	外 径 D <sub>2</sub>	各 部 寸 法				パドル突部 質 量 (kg)
		D <sub>5</sub>	K	a	L'₂	
75	93.0	185	18	5	25	2.91
100	118.0	210	18	5	25	3.46
150	169.0	280	22	5	25	6.73
200	220.0	330	22	5	25	8.22
250	271.6	390	24	5	25	11.5
300	322.8	445	24	5	25	13.7
350	374.0	500	26	5	25	17.3
400	425.6	560	28	5	25	22.3
450	476.8	620	30	5	25	28.1
500	528.0	675	30	5	25	31.6
600	630.8	795	32	6	30	45.0
700	733.0	905	34	7	35	58.2
800	836.0	1020	36	8	40	75.5
900	939.0	1130	38	9	45	93.4
1000	1041.0	1235	40	10	50	111
1100	1144.0	1345	42	11	55	134
1200	1246.0	1465	44	12	60	168
1350	1400.0	1630	48	14	70	220
1500	1554.0	1795	52	16	80	281